

# ECONOMY CHAIN HOIST WITH CHAIN CONTAINER - H-1000-3

APPROX WEIGHT: 84.00 lbs.

DOES NOT INCLUDE WEIGHT OF POWER OR PACKAGING!!!

\*\*\*ANY ADDITIONS, DELETIONS, OR OMISSIONS MUST BE CORRECTED ON THIS DRAWING AS THIS DRAWING WILL BE CONSIDERED ALL INCLUSIVE\*\*\*

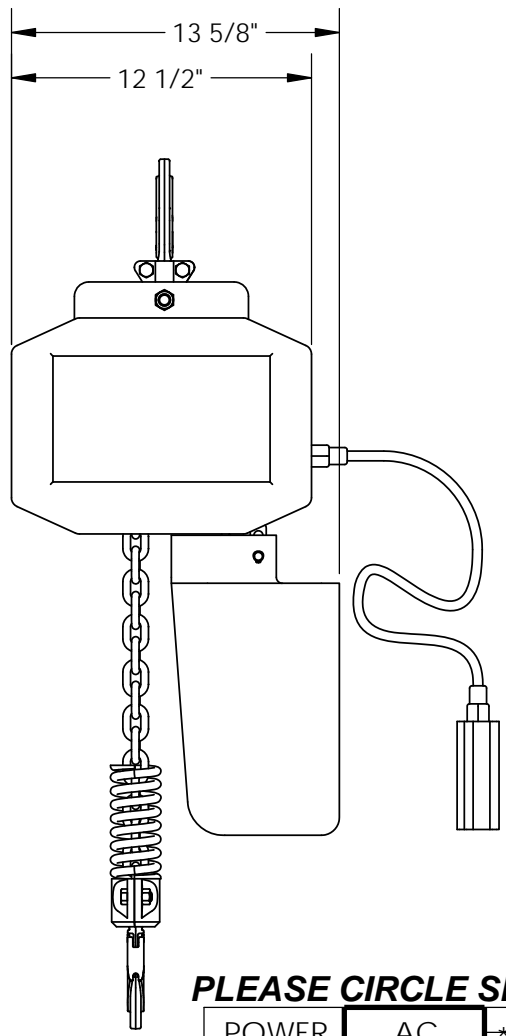
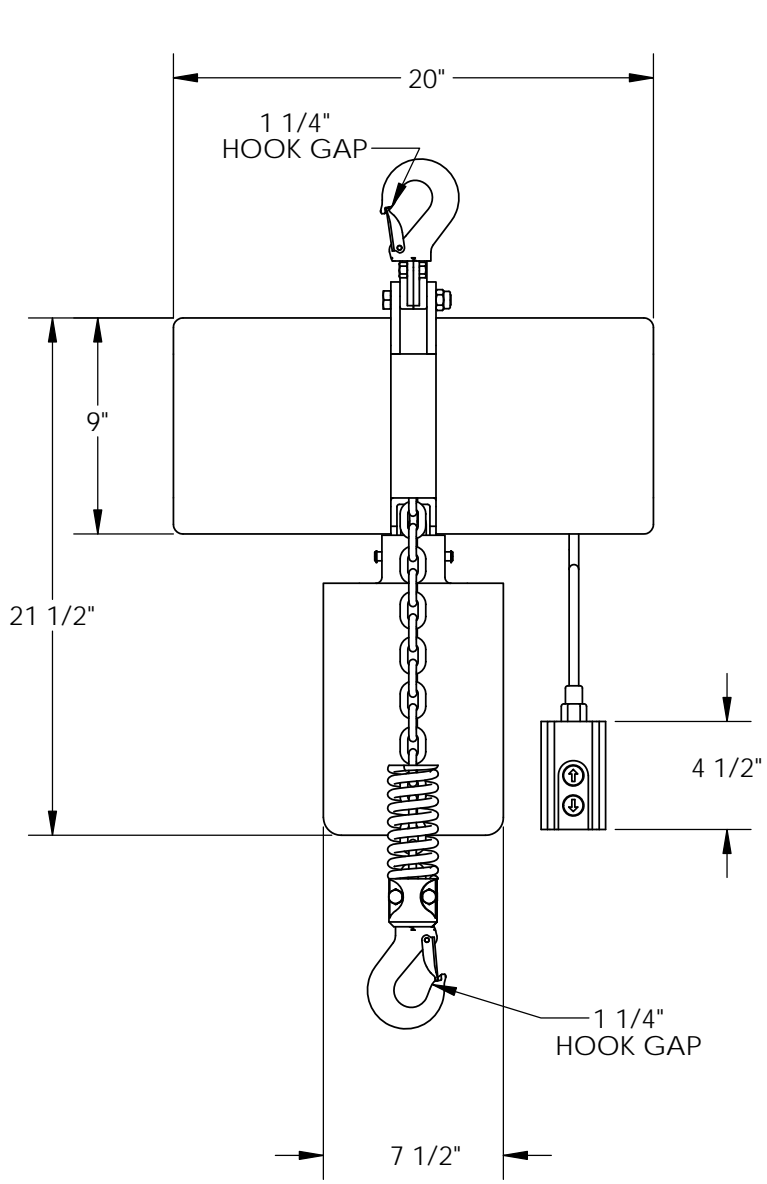

DIMENSION TOLERANCE  $\pm 1/4"$

**PLEASE CIRCLE SPECIFICATIONS:**

POWER	<input checked="" type="checkbox"/> AC	<input type="checkbox"/> * DC	<input type="checkbox"/> * AIR/OIL
MOTOR VOLTAGE	<input type="checkbox"/> 115	<input type="checkbox"/> 208	<input checked="" type="checkbox"/> 230 <input type="checkbox"/> 460
DEDICATED CIRCUIT REQUIRED			
MOTOR PHASE	<input type="checkbox"/> SINGLE	<input checked="" type="checkbox"/> THREE	
CONTROL	<input checked="" type="checkbox"/> HAND	<input type="checkbox"/> * FOOT	
~ ALL BATTERY CHARGERS ARE 115V AC ~			
* BATTERY CHRG.	<input type="checkbox"/> REMOTE	<input type="checkbox"/> ON-BOARD	
* CHRG. INDICATOR	<input type="checkbox"/> YES	<input type="checkbox"/> NO	

\* AVAILABLE AT ADDITIONAL COST

ALL GRAPHICS PROVIDED ARE FOR REFERENCE ONLY. IF CERTAIN DIMENSIONS ARE CRITICAL PLEASE VERIFY THOSE DIMENSIONS WITH YOUR SALESPERSON

**STANDARD FEATURES**

- MODEL NUMBER IS H-1000-3
- CAPACITY IS 1,000 LBS
- OVERALL WIDTH IS 12 1/2"
- OVERALL LENGTH IS 20"
- OVERALL HEIGHT IS 21 9/16"
- HEAD ROOM IS 21 7/16"
- FEET PER MINUTE IS 20 1/2'
- CHAIN LIFT LENGTH IS 15'
- REMOTE CORD LENGTH IS 15'

**SPECIAL FEATURES**

NONE

**A P P R O V A L**

I, THE UNDERSIGNED, AGREE THAT THE PRODUCT AS REPRESENTED SATISFIES DESIGN AND DIMENSION REQUIREMENTS. I ALSO ACKNOWLEDGE MY DUTY TO CONFIRM PRODUCT AND INSTALLATION COMPLIANCE WITH ALL APPLICABLE FEDERAL, STATE AND LOCAL REGULATIONS AND STANDARDS.

**ALL SPECIAL UNITS ARE NON-RETURNABLE**

[ ] As drawn [ ] As marked

Signed: \_\_\_\_\_ Date: \_\_\_\_\_

**LEAD TIME WILL START UPON RECEIPT OF SIGNED APPROVAL DRAWING**

DISTRIBUTOR'S NAME:		P.O.#
VESTIL MANUFACTURING		X
DRAWN BY: WHR		W.O.#
DATE: 6/21/12		X
REFERENCE: X	SCALE: 1:8	SALES: X
QUOTED LEAD TIME: X	QUOTE # X	FILE NAME:
		28-007-280