

ECONOMY CHAIN HOIST WITH CHAIN CONTAINER - H-1000-1

APPROX WEIGHT: 84.00 lbs.
 DOES NOT INCLUDE WEIGHT OF POWER OR PACKAGING!!!

ANY ADDITIONS, DELETIONS, OR OMISSIONS MUST BE CORRECTED ON THIS DRAWING AS THIS DRAWING WILL BE CONSIDERED ALL INCLUSIVE

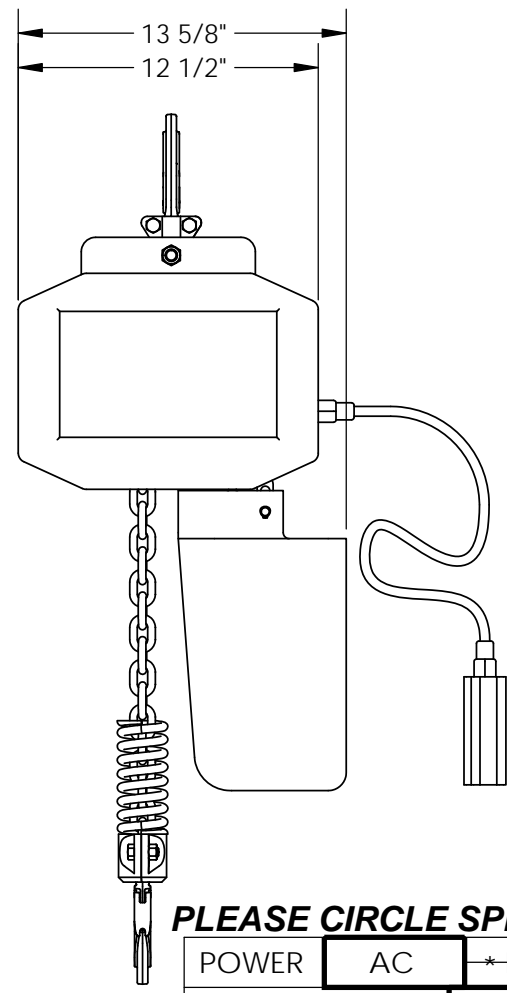
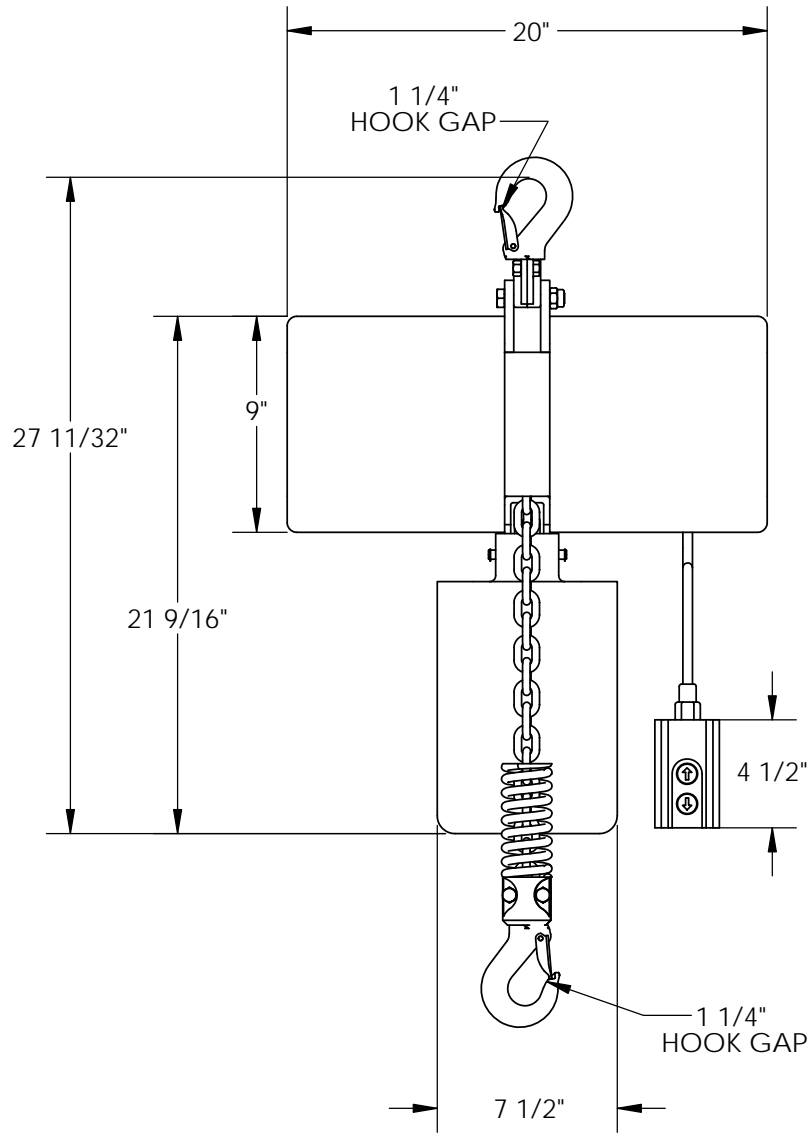

PLEASE CIRCLE SPECIFICATIONS:

POWER	<input checked="" type="checkbox"/> AC	<input type="checkbox"/> *DC	<input type="checkbox"/> * AIR/OIL	
MOTOR VOLTAGE	<input checked="" type="checkbox"/> 115	<input type="checkbox"/> 208	<input type="checkbox"/> 230	<input type="checkbox"/> 460
DEDICATED CIRCUIT REQUIRED				
MOTOR PHASE	<input checked="" type="checkbox"/> SINGLE		<input type="checkbox"/> THREE	
CONTROL	<input checked="" type="checkbox"/> HAND		<input type="checkbox"/> * FOOT	
~ ALL BATTERY CHARGERS ARE 115V AC ~				
* BATTERY CHRG.	<input type="checkbox"/> REMOTE	<input type="checkbox"/> ON-BOARD		
* CHRG. INDICATOR	<input type="checkbox"/> YES	<input type="checkbox"/> NO		

* AVAILABLE AT ADDITIONAL COST

DIMENSION TOLERANCE ± 1/4"

ALL GRAPHICS PROVIDED ARE FOR REFERENCE ONLY. IF CERTAIN DIMENSIONS ARE CRITICAL PLEASE VERIFY THOSE DIMENSIONS WITH YOUR SALESPERSON

STANDARD FEATURES

- MODEL NUMBER IS H-1000-1
- CAPACITY IS 1,000 LBS
- OVERALL WIDTH IS 13 5/8"
- OVERALL LENGTH IS 20"
- OVERALL HEIGHT IS 21 9/16"
- HEAD ROOM IS 21 7/16"
- FEET PER MINUTE IS 17'
- CHAIN LIFT LENGTH IS 15'
- REMOTE CORD LENGTH IS 15'

SPECIAL FEATURES

NONE

A P P R O V A L

I, THE UNDERSIGNED, AGREE THAT THE PRODUCT AS REPRESENTED SATISFIES DESIGN AND DIMENSION REQUIREMENTS. I ALSO ACKNOWLEDGE MY DUTY TO CONFIRM PRODUCT AND INSTALLATION COMPLIANCE WITH ALL APPLICABLE FEDERAL, STATE AND LOCAL REGULATIONS AND STANDARDS.

ALL SPECIAL UNITS ARE NON-RETURNABLE

[] As drawn [] As marked

Signed: _____ Date: _____

LEAD TIME WILL START UPON RECEIPT OF SIGNED APPROVAL DRAWING

DISTRIBUTOR'S NAME:		P.O.#
VESTIL MANUFACTURING		X
DRAWN BY: WHR		DATE: 6/21/12
REFERENCE: X		SCALE: 1:8
QUOTED LEAD TIME: X	QUOTE # X	FILE NAME: 28-007-273