

LOW PROFILE MANUAL TROLLEY- E-MT-2

APPROX WEIGHT: 21.02 lbs.
 DOES NOT INCLUDE WEIGHT OF POWER OR PACKAGING!!!

*** ANY ADDITIONS, DELETIONS, OR OMISSIONS MUST BE CORRECTED ON THIS DRAWING AS THIS DRAWING WILL BE CONSIDERED ALL INCLUSIVE ***

ALL GRAPHICS PROVIDED ARE FOR REFERENCE ONLY. IF CERTAIN DIMENSIONS ARE CRITICAL PLEASE VERIFY THOSE DIMENSIONS WITH YOUR SALESPERSON

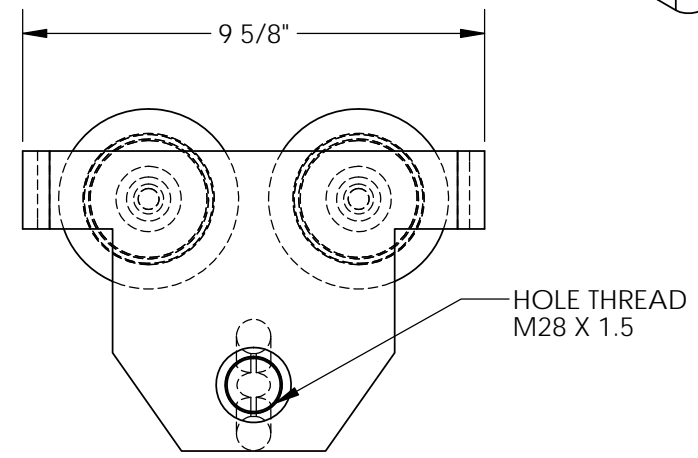
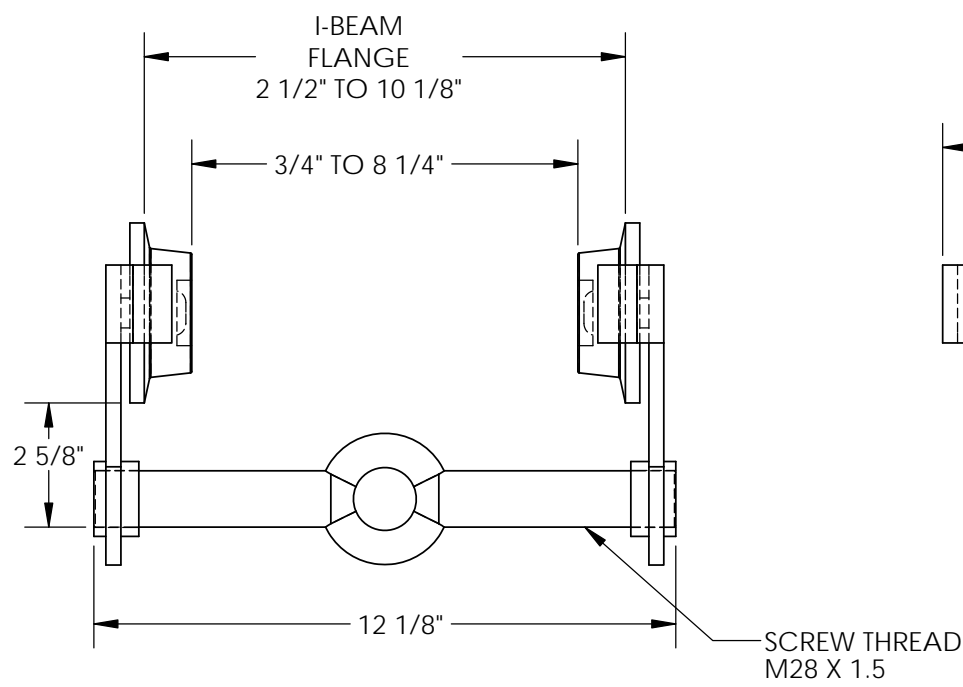
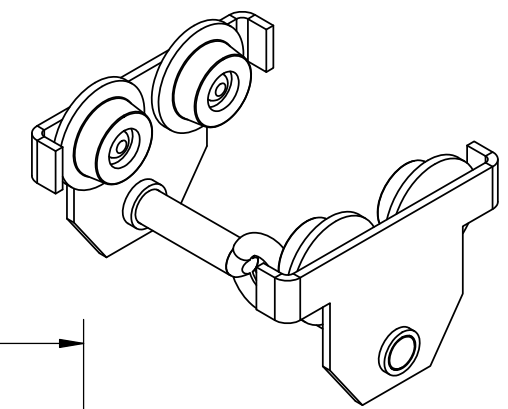

NOTE: USE ON "S" TYPE BEAM ONLY

STANDARD FEATURES

- MODEL NUMBER IS E-MT-2
- I-BEAM FLANGE 2 1/2" TO 10 1/8"
- USABLE WIDTH IS 9 5/8"
- OVERALL LENGTH IS 12 1/8"
- USABLE LENGTH IS 2 1/2" TO 10 1/8"
- HEADROOM IS 2 5/8"
- MAX CAPACITY IS 2,000 LBS.

SPECIAL FEATURES

NONE

DIMENSION TOLERANCE ± 1/4"

APPROVAL	I, THE UNDERSIGNED, AGREE THAT THE PRODUCT AS REPRESENTED SATISFIES DESIGN AND DIMENSION REQUIREMENTS. I ALSO ACKNOWLEDGE MY DUTY TO CONFIRM PRODUCT AND INSTALLATION COMPLIANCE WITH ALL APPLICABLE FEDERAL, STATE AND LOCAL REGULATIONS AND STANDARDS.	
	ALL SPECIAL UNITS ARE NON-RETURNABLE	
	[] As drawn [] As marked	
Signed: _____		Date: _____
LEAD TIME WILL START UPON RECEIPT OF SIGNED APPROVAL DRAWING		

DISTRIBUTOR'S NAME:		P.O.#
VESTIL MANUFACTURING		X
DRAWN BY: CA		W.O.#
DATE: 05/02/2012		X
REFERENCE: X	SCALE: 1:4	SALES: X
QUOTED LEAD TIME: X	QUOTE #	FILE NAME:
	X	30-007-230