

GEARED EYE MANUAL TROLLEY - E-MT-10-C

APPROX WEIGHT: 97.48 lbs.
 DOES NOT INCLUDE WEIGHT OF POWER OR PACKAGING!!!

*** ANY ADDITIONS, DELETIONS, OR OMISSIONS MUST BE CORRECTED ON THIS DRAWING AS THIS DRAWING WILL BE CONSIDERED ALL INCLUSIVE ***

ALL GRAPHICS PROVIDED ARE FOR REFERENCE ONLY. IF CERTAIN DIMENSIONS ARE CRITICAL PLEASE VERIFY THOSE DIMENSIONS WITH YOUR SALESPERSON

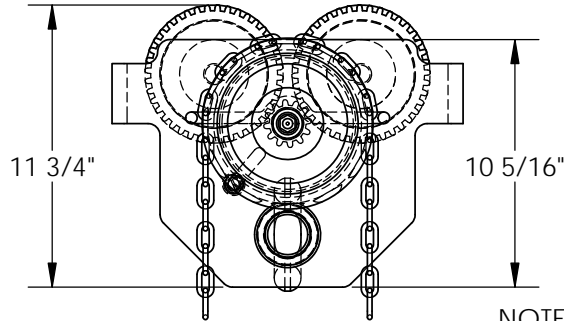
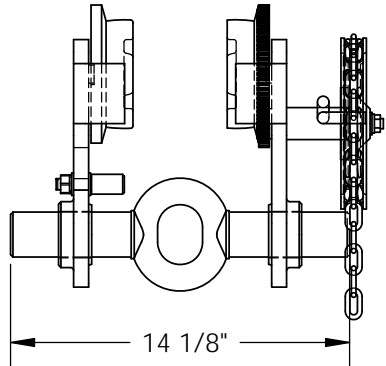
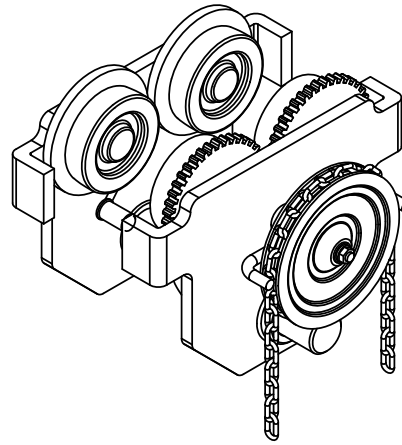
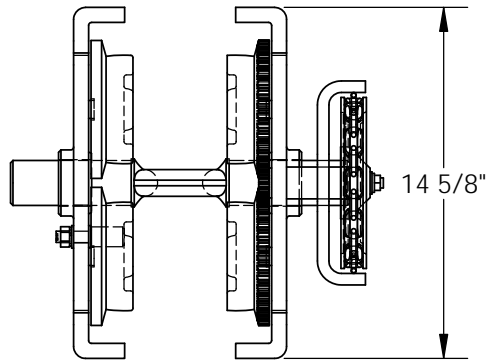

NOTE: FULL CHAIN LENGTH NOT SHOWN

STANDARD FEATURES

- MODEL NUMBER IS E-MT-10-C
- OVERALL WIDTH IS: 14 1/8"
- OVERALL LENGTH IS: 14 5/8"
- OVERALL HEIGHT IS: 11 3/4"
- MAX CAPACITY IS: 10,000 LBS.
- I-BEAM FLANGE RANGE IS: 3"-9"
- TROLLEY WIDTH IS ADJUSTABLE BY ROTATING CENTER ROD

NOTE: USE ON "S" TYPE BEAM ONLY

SPECIAL FEATURES

NONE

A P P R O V A L

I, THE UNDERSIGNED, AGREE THAT THE PRODUCT AS REPRESENTED SATISFIES DESIGN AND DIMENSION REQUIREMENTS. I ALSO ACKNOWLEDGE MY DUTY TO CONFIRM PRODUCT AND INSTALLATION COMPLIANCE WITH ALL APPLICABLE FEDERAL, STATE AND LOCAL REGULATIONS AND STANDARDS.

ALL SPECIAL UNITS ARE NON-RETURNABLE

[] As drawn [] As marked

Signed: _____ Date: _____

LEAD TIME WILL START UPON RECEIPT OF SIGNED APPROVAL DRAWING

DISTRIBUTOR'S NAME:		P.O.#
VESTIL MANUFACTURING		X
DRAWN BY: T. MOORE		W.O.#
DATE: 12/14/09		X
REFERENCE: X	SCALE: 1:8	SALES: X
QUOTED LEAD TIME: X	QUOTE #	FILE NAME:
	X	30-007-136