

FORK MOUNTED RUG-RAM - CRF-144

APPROX WEIGHT: 413.35 lbs.
 DOES NOT INCLUDE WEIGHT OF POWER OR PACKAGING!!!

*** ANY ADDITIONS, DELETIONS, OR OMISSIONS MUST BE CORRECTED ON THIS DRAWING AS THIS DRAWING WILL BE CONSIDERED ALL INCLUSIVE ***

ALL GRAPHICS PROVIDED ARE FOR REFERENCE ONLY. IF CERTAIN DIMENSIONS ARE CRITICAL PLEASE VERIFY THOSE DIMENSIONS WITH YOUR SALESPERSON

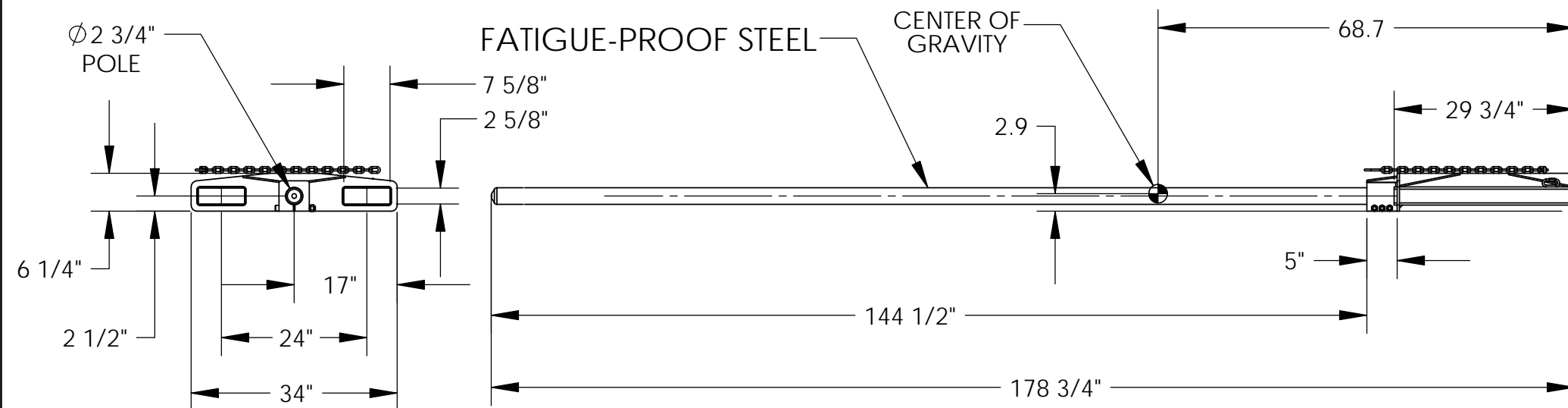

HORIZONTAL CENTER OF GRAVITY: 68.7"
 VERTICAL CENTER OF GRAVITY: 2.9
 LOST LOAD: 420 LBS. (APPROX.)

STANDARD FEATURES

MODEL NUMBER: CRF-144
 CAPACITY: 1,800 LBS. UNIFORM CAPACITY
 POLE LENGTH: 144 1/2"
 POLE DIAMETER: 2 3/4"
 FORK POCKETS ARE 7 5/8" W x 2 5/8" H
 USABLE ON 24" FORK CENTERS
 WITH SAFETY CHAIN TO SECURE TO THE
 UNIT TO THE MAST OF THE FORK TRUCK

SPECIAL FEATURES

NONE

NEVER EXCEED LOAD CENTER RATING PER
 FORK TRUCK MANUFACTURER'S GUIDELINES.
 DO NOT USE THIS FORK TRUCK ATTACHMENT
 IF LOAD WILL EXCEED FORK TRUCK
 MANUFACTURER'S LOAD CENTER RATING.

APPROVAL	I, THE UNDERSIGNED, AGREE THAT THE PRODUCT AS REPRESENTED SATISFIES DESIGN AND DIMENSION REQUIREMENTS. I ALSO ACKNOWLEDGE MY DUTY TO CONFIRM PRODUCT AND INSTALLATION COMPLIANCE WITH ALL APPLICABLE FEDERAL, STATE AND LOCAL REGULATIONS AND STANDARDS.	
	ALL SPECIAL UNITS ARE NON-RETURNABLE <input type="checkbox"/> As drawn <input type="checkbox"/> As marked	
	Signed: _____	Date: _____
LEAD TIME WILL START UPON RECEIPT OF SIGNED APPROVAL DRAWING		

DISTRIBUTOR'S NAME:		P.O.#
VESTIL MANUFACTURING		X
DRAWN BY: BJW		W.O.#
DATE: 1/12/2008		X
REFERENCE: X	SCALE: 1:24	SALES: X
QUOTED LEAD TIME: X	QUOTE # X	FILE NAME:
		08-007-158