

Stainless stacker - hygienic handling of goods

Optimum hygiene - with the stainless-steel Trans-Stacker the risk of bacterial contamination is minimized.

The stainless-steel products are developed for environments where severe hygiene is needed on the surfaces that are in direct contact with the goods being handled, e.g. meat, fish or medicine.

The design focuses on the safety and ergonomic working conditions of the user. As an example, the ergonomically correct handle ensures the user a relaxed hold.

High quality is ensured through an extended test program and in cooperation with experts in Health and Safety.



Technical Specifications

Optimum safety for the user through

- central location of all control buttons on the handle
- transparent and impact-resistant safety screen on the mast
- location of parking brake

Strong construction ensures a long operating life and low maintenance costs.



The ergonomically correct handle ensures the user a relaxed hold.



Closed forks mean easy cleaning and few hiding places for bacteria.



TS-E STAINLESS-SEMI has assisted wheel steering. Easy and hygienic operations.

Available with manual or electric lifting.

Product (measured in inch)	TS-M STAINLESS-SEMI					TS-E STAINLESS-SEMI						
	2200	2200	2200	2200	2200	2200	2200	2200	2200	2200	2200	2200
Capacity in lbs.	2200	2200	2200	2200	2200	2200	2200	2200	2200	2200	2200	2200
Lifting height h_3	47	55	63	80	96	47	55	63	80	96	112	
Fork length l	45					45						
Overall height h_1	60	68	76	60	68	60	68	76	60	68	76	
Overall width b_1	25.75				913	26.5					36.75	
Fork span b_5	22					22						
Length without forks l_2	15.25					19.50						
Overall length by 1150 forks l_1	65			65.25		67.5			68			
Overall height h_4	Without telescopic mast			98	114	Without telescopic mast			98	114	130	
Lowered height h_{13}	3.5					3.5						
Load centre c	max. 23.5					max. 23.5						
Fork width e	6.5					6.5						
Run-in length l_x	39.5					39.5						
Gangway (pallet: 47" x 31.5") A_{st}	79*					86.5**						
Free lift	7.5					7.5						
Turning angle of the wheels	180°					180°						
Pump motor						1,1 kW 12 V						
Lifting speed	normal/quick 0.75/2 mm per pump					with/without load: 2.75" per sec.						
Lowering speed irrespective of load	8.25" per sec.					3" per sec.						
Weight in lbs. (without battery)	425	433	442	561	581	479	488	497	623	642	664	

* Tests show that 27" are enough.

** Tests show that 60" are enough.



STAINLESS-SEMI - for the food industry and other environments with strict hygiene demands.

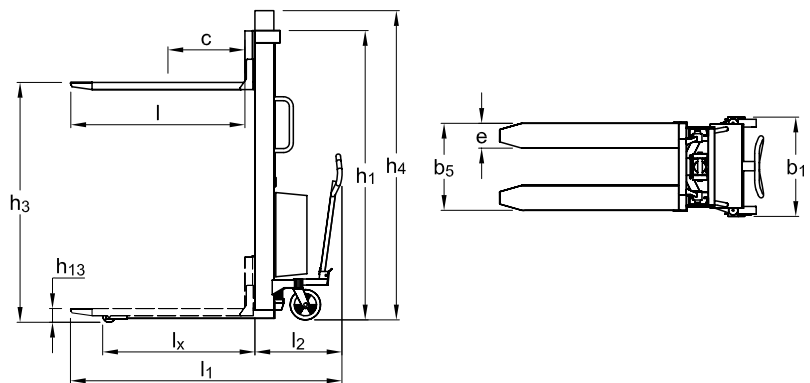

Please ask for specification details or visit www.interthor.com
We also offer tailor-made solutions.